



Basics of the DRC 300

1.) What is a DRC 300?

The DRC 300 is a radio controlled miniature DCC central station. The DRC 300 may be connected to any NMRA compatible decoder.

2.) What are the most important benefits and areas of operation?

With a Navigator and a DRC 300 you have an independent digital wireless system. You can operate any digital loco on any track anywhere, whether it is your home or you take the loco to your friend's layout, you put your train on his track and you are ready.

You already have the great DiMAX central station: now you are independent from any weather restrictions and can run a cleaning loco or snow plow at any given time, no track power needed, just a battery pack.

The analog driver can now utilize the benefits of a digital system without any major changes to his system.

Show displays are set-up fast and easy and operated without any exterior power supply.

With an additional DRC 300 you may do wireless switch control in analog layouts.

3.) What you need to get started:

- A DiMAX wireless Navigator (transmitter) with software 2.0 and up (older version may be updated).
- A locomotive with an NMRA compatible DCC decoder.
- A DRC 300 receiver.
- A power supply for the receiver and the decoder (regular batteries, rechargeable batteries or ANY track power)

4.) How far can the system be expanded?

- The system allows up to 8 transmitters (Navigators) and 8 receivers (DRC 300).
- Up to 8 locomotives may be operated at the same time. (Addresses 1 – 10239)
- Operate an unlimited number of switches.
- Up to 8 Navigators may operate at the same time

5.) What are my decoder limitations?

Basically none – you may use **all NMRA compatible** decoders (e.g. Massoth, LGB onboard decoders, Bachmann, Phoenix etc. (check complete list on www.massoth.com later this month).

6.) Why do we use a miniature RC DCC central station instead of a wireless decoder

- You need only one receiver type for all applications: small and large locos with and without sound, coaches and cars and switches.

- The receiver may be installed into any loco or car already carrying an NMRA compatible decoder.
- Separating the motor control part from the receiver module improves the receiving quality.
- Changing from DRC 300 & Navigator to the MASSOTH DIMAX central station system is easy as apple pie. The central station digital system of course allows you to automatically control several (up to 32) locos at the same time.
- The DRC 300 can be easily installed into any locos already equipped with DCC decoders.
- By adding an input control switch the locomotive may be controlled by either RC or by a regular DCC system (see illustration 3).

7.) What is the range of the DRC 300?

Basically the range will be the same as the range with the DiMAX DCC system. However the position of the antenna in the locomotive may reduce the range a little. We utilize a state-of-the-art bi-directional RC system with FEC (forward error correction) to ensure the best range and optimum reliability. A minimum range of 500 ft should be achievable.

8.) What happens in case of a signal loss?

You may program several system characteristics to take care of this situation:

- The locomotive stops immediately
- The locomotive continues for a preset time (e.g. to get out of a tunnel)
- The locomotive continues until new commands are received

9.) May I use all features of a digital control system?

Basically YES. All control commands and functions of the Navigator are available:

- Drive a locomotive, control the lights and the functions
- Control switches and switch routes
- Install and operate consists
- Program CVs and read CVs

10.) May I control a central station and the DRC 300 at the same time?

Technically this is possible. However, the first version will be restricted to either RC or DCC operation. We are considering changing this later with a software upgrade.

11.) Which power source is required?

The DRC 300 may be operated by a (rechargeable) battery (min. 10 Volts) or via an additional rectifier by any kind of track power (max. 22 Volts DC). See illustrations 1 and 2

12.) What are the big advantages over other RC systems?

- The DRC 300 is 100% NMRA compatible. This is **not** a siled application for the RC operation!
- The Navigator is still usable for all other applications: DiMAX, MTS-III, XpressNet
- You may use the already installed DCC decoders.

13.) What are the cons compared to other RC systems?

The starting price tag is a little higher because the receiver does not contain a decoder. However, this must be put into perspective with the compatibility of the components.

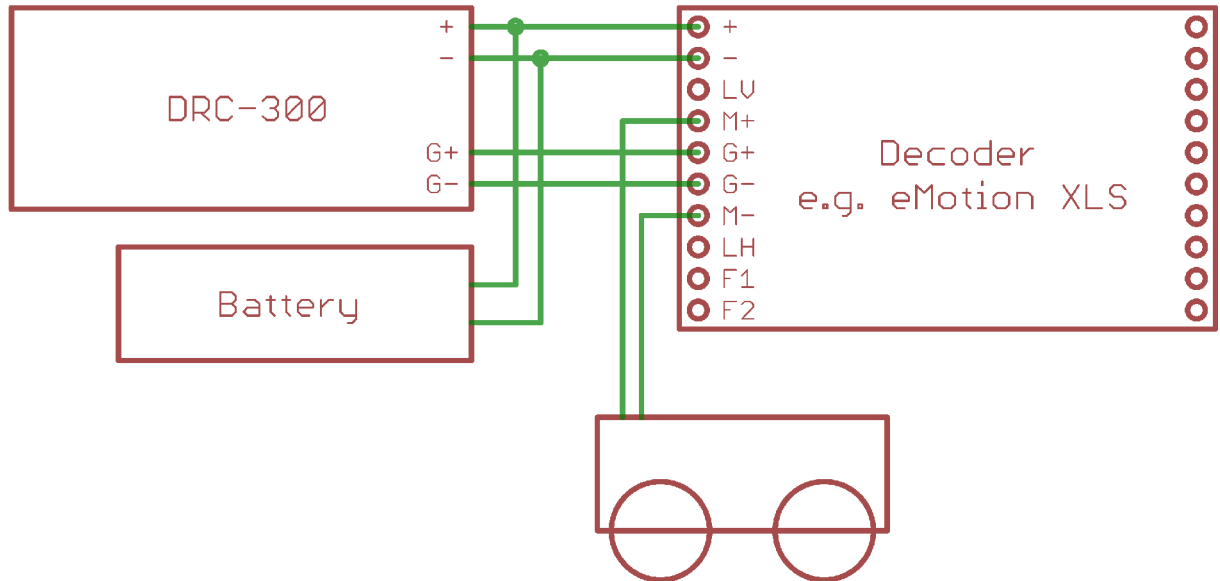

Illustration 1: Hook-up for battery operation

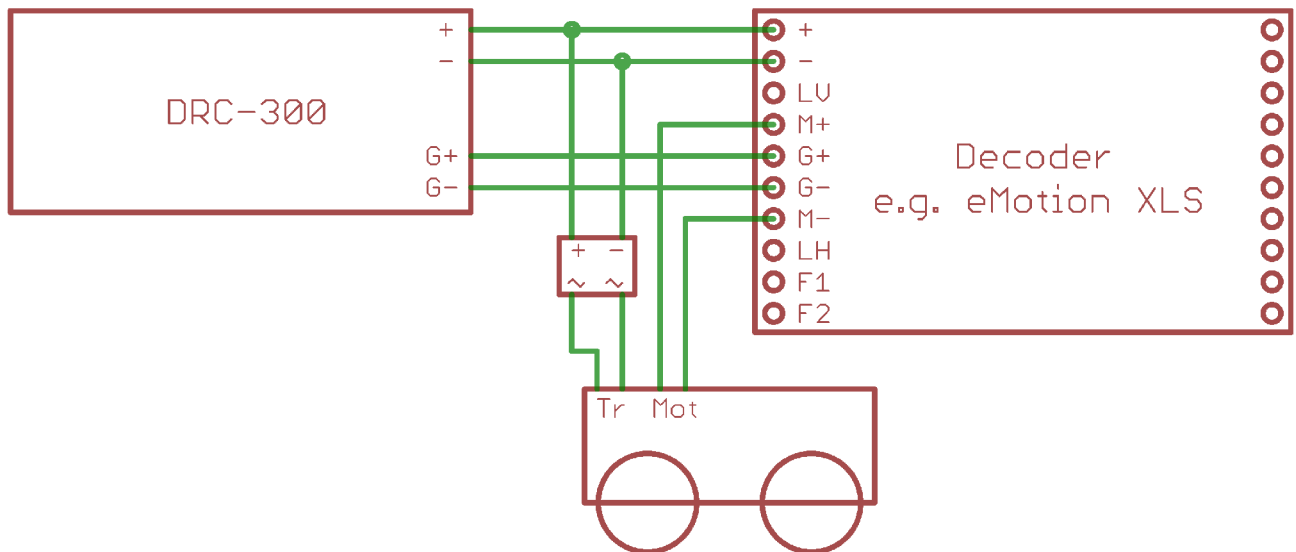

Illustration 2: Hook-up for track power operation

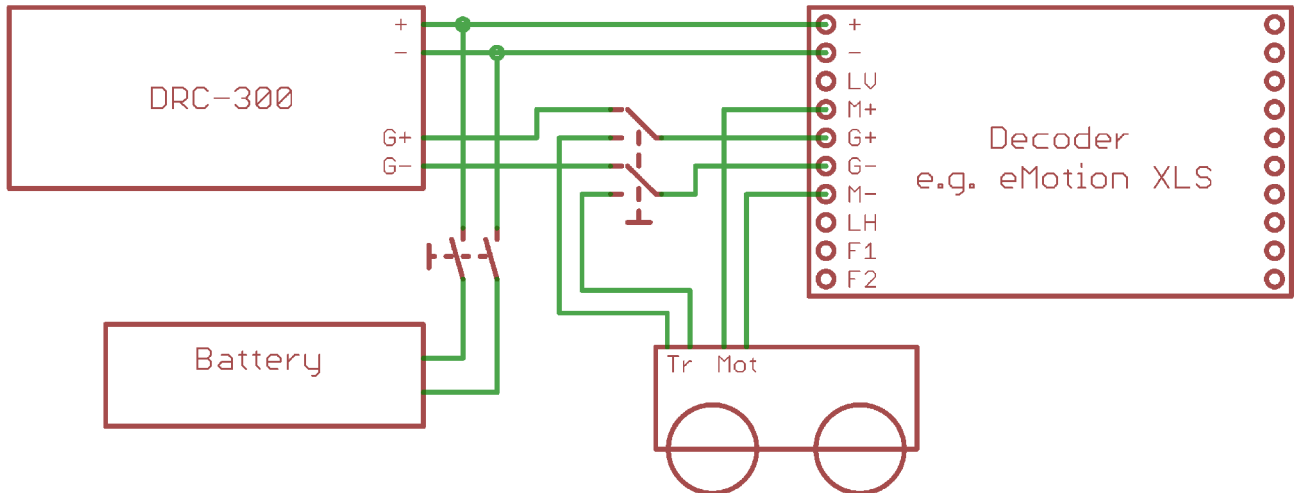

Illustration 3: Hook-up with selector switch RC/digital track power